



MENEGOTTI
máquinas e equipamentos

FORTE COMO
CONCRETO

Máquina Manual de Blocos e Pavimentos MBM-3

MBM-3 Manual Block an Paver Machine

Máquina Manual de Bloques y Adoquines MBM-3



> Operação manual.

Operating manual.
Operación manual.

> Possui mesa de vibração para melhor compactação do concreto.

Supplied with vibration table for better concrete compaction.
Posee mesa de vibración para mejor compactación del hormigón.

> Versátil.

Produz blocos e pavimentos.

Versatile. Produces blocks and pavers.
Versátil. Produce bloques y adoquines.



Blocos e Pavimentos

Blocks and pavers
Bloques y adoquines









Assista ao vídeo no Youtube
Watch the video on Youtube
Vea el vídeo en Youtube





Quadro estimativo de produção em 8 horas de trabalho e capacidade nominal de 100%. | Estimated values based on an 8 hour working day and 100% nominal rate. | Tabla estimativa de producción en 8 horas de trabajo y capacidad nominal de 100%.

Descrição Description Descripción	Peças por molde Parts per mold Piezas por molde	Peças por dia Parts per day Piezas por día	Ciclos/min. Cycles/min. Ciclos/min.	m ² por dia m ² per day m ² por día
 Pavimento: Pavi "S" Brick paver: Paver "S" Adoquín tipo: Pavi "S"	6	4.320 - 5.500	1,5 - 2,0	90 - 110
 Pavimento: 200 x 100 x 80 mm Paving stone: 200 x 100 x 80 mm Adoquín: 200 x 100 x 80 mm	8	5.760 - 7.500	1,5 - 2,0	110 - 150
 Lajota sextavada 250 mm Hexagonal paver 250 mm Adoquín hexagonal 250 mm	1	720 - 900	1,5 - 2,0	40 - 50
 Bloco 90 x 190 x 390 mm Block 90 x 190 x 390 mm Bloque 90 x 190 x 390 mm	4	1.900	1,0	-
 Bloco 140 x 190 x 390 mm Block 140 x 190 x 390 mm Bloque 140 x 190 x 390 mm	3	1.400	1,0	-
 Bloco 190 x 190 x 390 mm Block 190 x 190 x 390 mm Bloque 190 x 190 x 390 mm	2	950	1,0	-

Nota | Note | Nota: Os valores constantes do quadro acima podem sofrer variações em função das condições de operação: tipos de matérias-primas, qualificação e treinamento da mão de obra, trocas de moldes, períodos de limpeza e manutenção do equipamento e/ou sua falta, casos fortuitos ou de força maior. | The above data may vary under working conditions: raw material types, labor qualification and training skills, mold setups, cleaning and maintenance tasks and/or the lack thereof, or force majeure. | Los valores constantes en el cuadro arriba pueden sufrir cambios en función de las condiciones de operación, tipos de materias-primas, calificación y capacitación de mano de obra, cambios de moldes, períodos de limpieza y mantenimiento del equipo y/o su falta, casos de fuerza mayor.

Dados técnicos

Technical data | Datos técnicos

Peso da máquina

Machine weight | Peso de la máquina

≈340 kg

Voltagem: trifásico

Voltage: three-phase | Voltaje: trifásico

220 / 380 V

Potência total instalada

Total installed power | Potencia total instalada

2 cv - 60 Hz
3 cv - 50 Hz

Dimensões dos paletes

Pallets dimensions | Dimensiones de los pallets

Madeira | Wood | Madera

440 x 440 x 15 mm

480 x 540 x 15 mm

Dimensões do conjunto montado

Assembled set dimensions | Dimensiones del conjunto montado

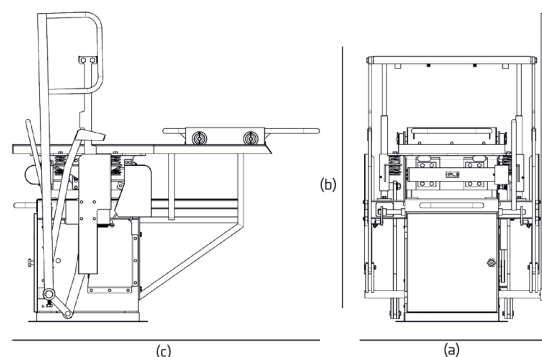

(a) Largura | Width | Ancho: 102 mm

(b) Altura | Height | Altura: 169 mm

(c) Comprimento | Length | Largo: 143 mm

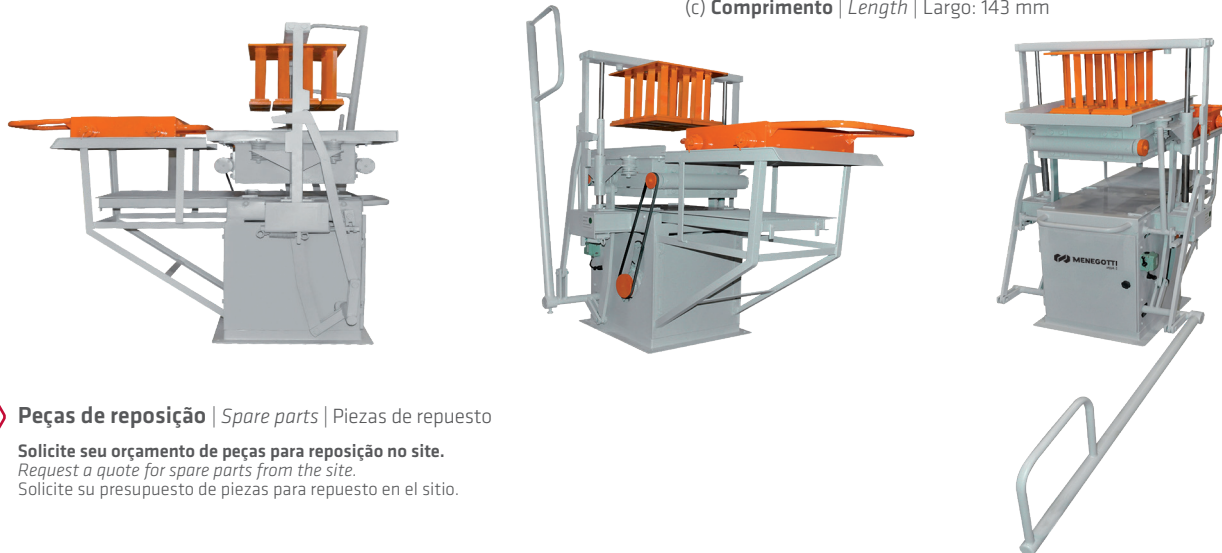

Peças de reposição | Spare parts | Piezas de repuesto

Solicite seu orçamento de peças para reposição no site.

Request a quote for spare parts from the site.

Solicite su presupuesto de piezas para repuesto en el sitio.



Rua Erwino Menegotti, 345 | Jaraguá do Sul - SC - Brasil | 89254-000
Fone: (55) 47 2107-2100 | Fax: (55) 47 2107-2101 | falecom@menegotti.net | menegotti.net

 facebook.com/menegotti.net

 youtube.com/mktmenegotti